

Pakon ISODORN HQW®



Our products from the division BUILDING SOLUTIONS

SERVICES

- » On-site tests -> we ensure that your requirements are properly covered by our planning.
- » Test reports -> for your safety and documentation.
- » Trainings -> the knowledge of your employees from planning and production is enhanced by our experts on site, online or via webinar.
- » Planning support -> latest design software, planning documents, CAD data and much more can be downloaded any time from www.philipp-group.de.

HIGH DEMANDS ON PRODUCT SAFETY AND PRACTICALITY

- » Close cooperation with notified bodies and - if necessary - approval of our solutions.

TECHNICAL DEPARTMENT

- » Our expert-team will support you at any time during your planning phase with detailed advice.

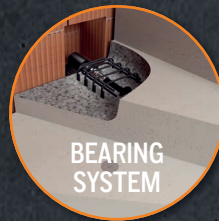
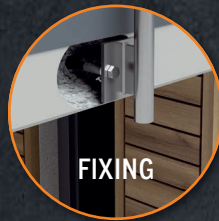
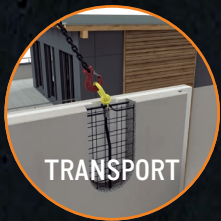

Approval body for construction products
and types of construction

Bautechnisches Prüfamt

An institution established by the Federal and
Laender Governments



European Technical Assessment

**ETA-19/0401
of 26 February 2020**

English translation prepared by DIBt - Original version in German language

General Part

Technical Assessment Body issuing the
European Technical Assessment:

Deutsches Institut für Bautechnik

Trade name of the construction product

Pakon - Trittschallboxen HQW

Product family
to which the construction product belongs

Dowels for structural joints under static and quasi-static
loading

Manufacturer

Pakon AG
Bahnhofstraße 33
8867 NIEDERURNEN
SCHWEIZ

Manufacturing plant

Pakon AG
M 20 Areal, Wasterkingerweg 2
8193 Eglisau-Hüntwangen
SCHWEIZ

This European Technical Assessment
contains

20 pages including 3 annexes which form an integral part
of this assessment

This European Technical Assessment is
issued in accordance with Regulation (EU)
No 305/2011, on the basis of

ETAG 030, Part 1 version April 2013, used as EAD
according to Article 66 Paragraph 3 Regulation (EU)
No 305/2011



European Technical Assessment
ETA-19/0401
English translation prepared by DIBt

Page 2 of 20 | 26 February 2020

The European Technical Assessment is issued by the Technical Assessment Body in its official language. Translations of this European Technical Assessment in other languages shall fully correspond to the original issued document and shall be identified as such.

Communication of this European Technical Assessment, including transmission by electronic means, shall be in full. However, partial reproduction may only be made with the written consent of the issuing Technical Assessment Body. Any partial reproduction shall be identified as such.

This European Technical Assessment may be withdrawn by the issuing Technical Assessment Body, in particular pursuant to information by the Commission in accordance with Article 25(3) of Regulation (EU) No 305/2011.

Specific Part

1 Technical description of the product

The impact sound box HQW consists of three functional units sound insulation box, bearing element and sleeve with gantry steel plate. The bearing element (hollow steel profile) is approved in the variants of galvanized steel and stainless steel. The impact sound box HQW is approved in the types HQW-60/40 and HQW-60/60.

The detailed product description is given in Annex A.

2 Specification of the intended use in accordance with the applicable European Assessment Document

The performances given in Section 3 are only valid if the Product is used in compliance with the specifications and conditions given in Annex B.

The verifications and assessment methods on which this European Technical Assessment is based lead to the assumption of a working life of the Product of at least 50 years. The indications given on the working life cannot be interpreted as a guarantee given by the producer, but are to be regarded only as a means for choosing the right products in relation to the expected economically reasonable working life of the works.

3 Performance of the product and references to the methods used for its assessment

3.1 Mechanical resistance and stability (BWR 1)

Essential characteristic	Performance
Resistance	Annex C1 and Annex C2

3.2 Safety in case of fire (BWR 2)

Essential characteristic	Performance
Reaction to fire	class A1

4 Assessment and verification of constancy of performance (AVCP) system applied, with reference to its legal base

In accordance with ETAG 030, Part 1 the applicable European legal act is: [2003/639/EC(EU)].

The system(s) to be applied is (are): [2+]

In addition, with regard to reaction to fire for products covered by this ETAG the applicable European legal act is: Decision 96/603/EC

The system to be applied is: [4]

European Technical Assessment
ETA-19/0401
English translation prepared by DIBt

Page 4 of 20 | 26 February 2020





5 Technical details necessary for the implementation of the AVCP system, as provided for in the applicable EAD

Technical details necessary for the implementation of the AVCP system are laid down in the control plan deposited with Deutsches Institut für Bautechnik.

Issued in Berlin on 26 February 2020 by Deutsches Institut für Bautechnik

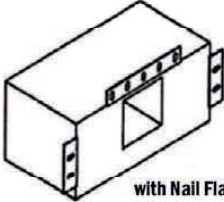
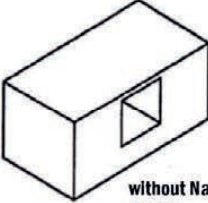
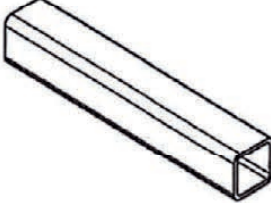
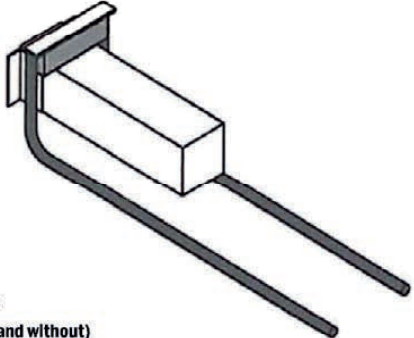
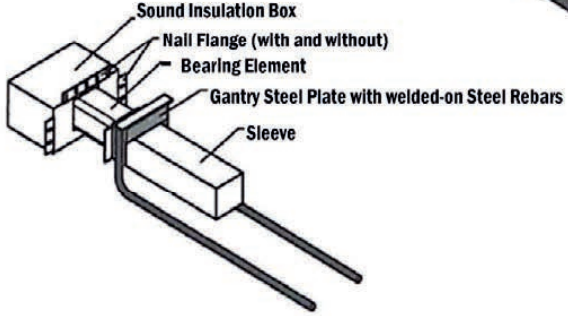
BD Dipl.-Ing. Andreas Kummerow
Head of Department

beglaubigt:
Schüler

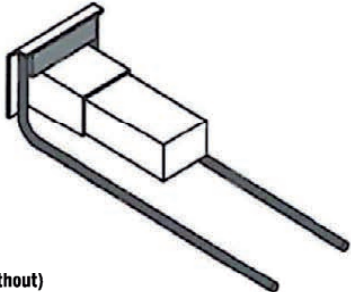
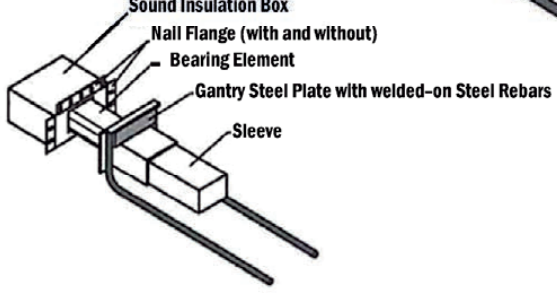
<u>HQW 60 / 60</u>		
<p>Sound Insulation Box</p>  <p>with Nail Flange</p>  <p>without Nail Flange</p>	<p>Bearing Element Hollow Steel Profile</p> 	<p>Sleeve with Gantry Steel Plate</p> 
 <p>Sound Insulation Box Nail Flange (with and without) Bearing Element Gantry Steel Plate with welded-on Steel Rebars Sleeve</p>		
<u>HQW 60 / 40</u>		
<p>Sound Insulation Box</p>  <p>with Nail Flange</p>  <p>without Nail Flange</p>	<p>Bearing Element Hollow Steel Profile</p> 	<p>Sleeve with Gantry Steel Plate</p> 
 <p>Sound Insulation Box Nail Flange (with and without) Bearing Element Gantry Steel Plate with welded-on Steel Rebars Sleeve</p>		
Pakon – Trittschallbox HQW		Annex A1
Product Specification System Overview		

HQW 60/60 (Sleeve, galvanised sheet metal)

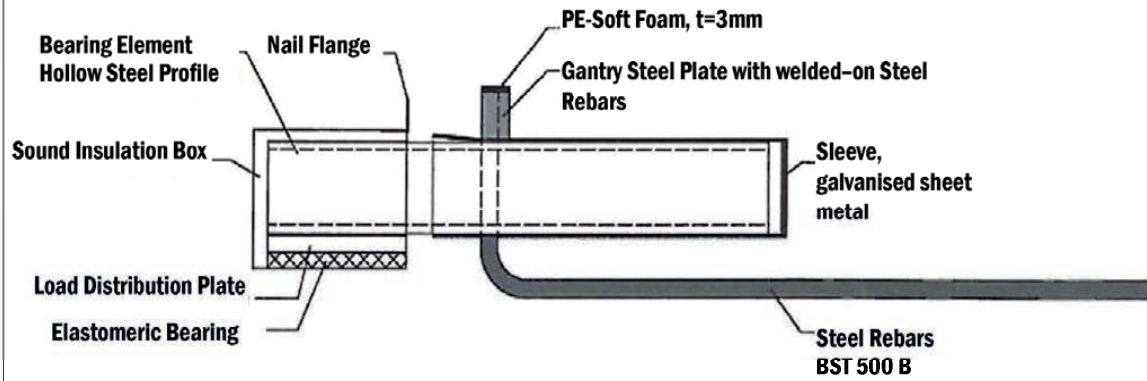

HQW 60/60 and HQW 60/40 (Sleeve, syntetic)

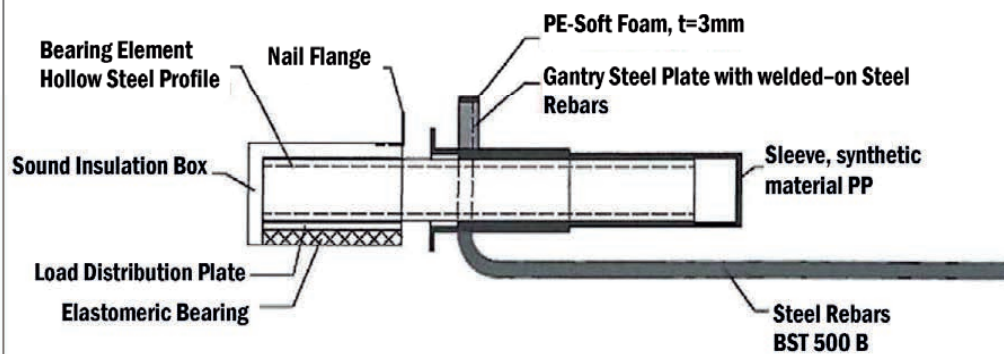

Pakon – Trittschallbox HQW

Product Specification
Materials

Annex A2

HQW 60 / 60

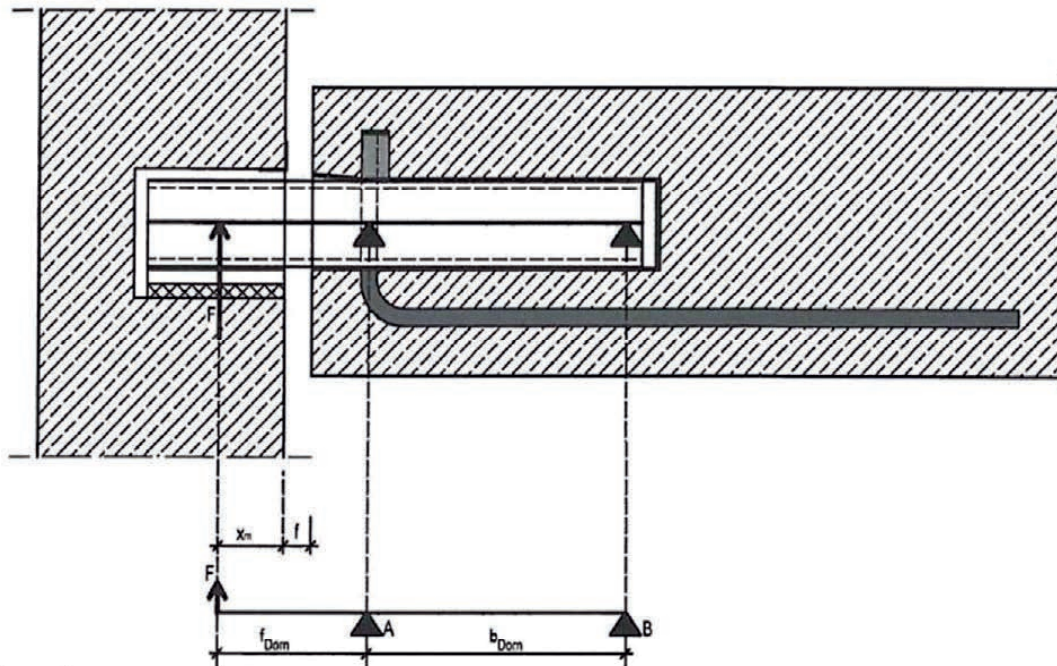

HQW 60 / 40

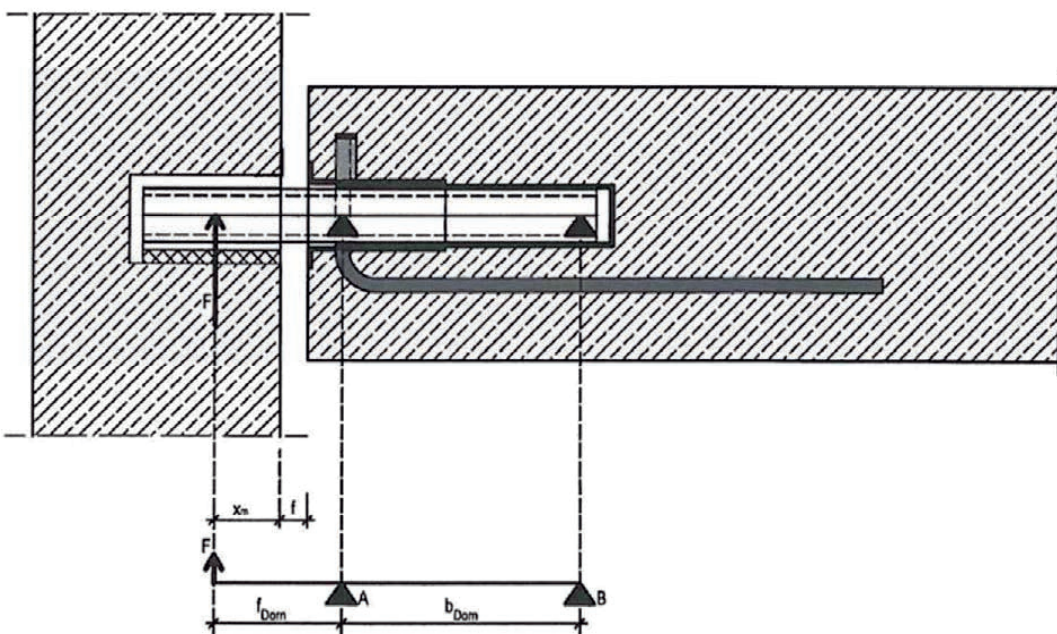

Pakon – Trittschallbox HQW

Product Specification
Statical System

Annex A3

Sleeve with Gantry Steel Plate for HQW 60/60 (Sleeve, galvanised sheet metal)

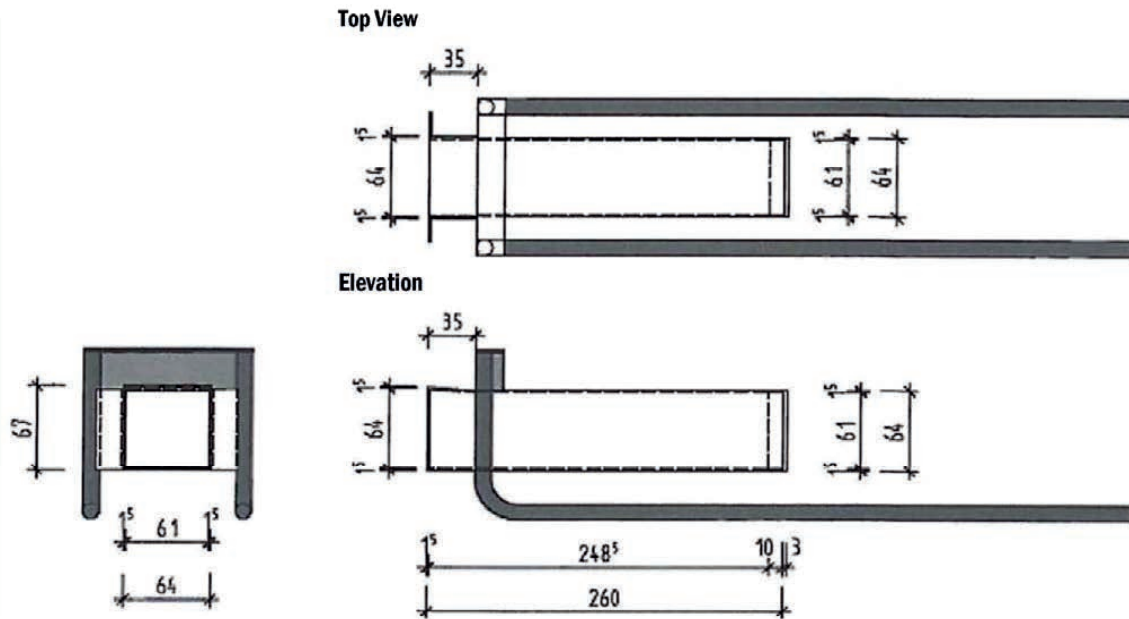

Sleeve (synthetic) for HQW 60/40 and HQW 60/60 (values in brackets)

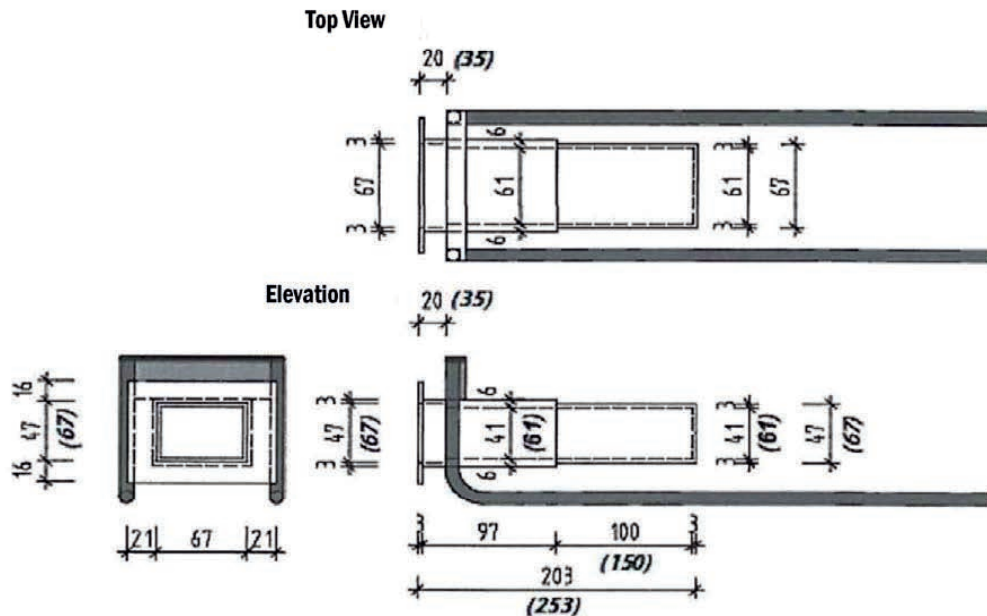

Pakon – Trittschallbox HQW

Product Specification

Dimensions and Designation of Sleeve with Gantry Steel Plate

Annex A4

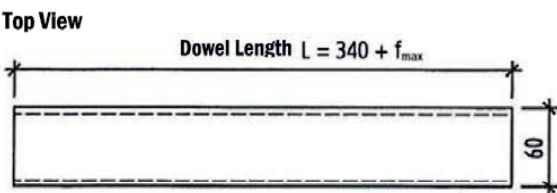
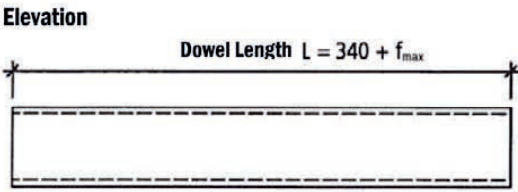
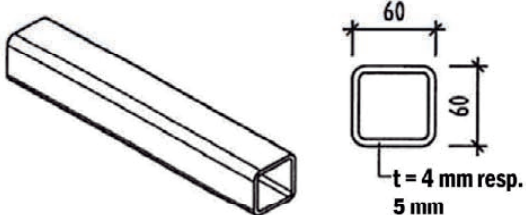
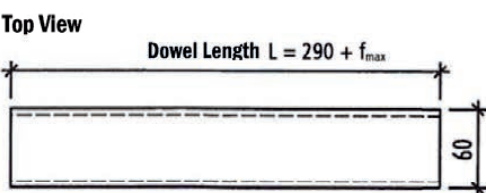
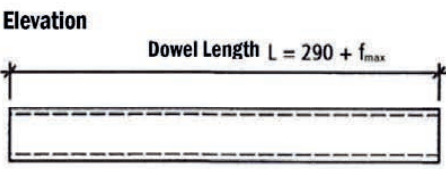
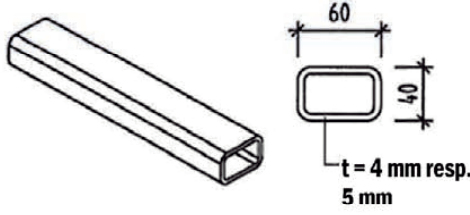
<p>HQW 60 / 60</p> <p>Bearing Element Hollow Steel Profile</p> <p>Top View</p>  <p>Dowel Length $L = 340 + f_{max}$</p> <p>60</p> <p>Elevation</p>  <p>Dowel Length $L = 340 + f_{max}$</p>  <p>60</p> <p>60</p> <p>$t = 4 \text{ mm resp. } 5 \text{ mm}$</p> <p>Material: S 275 galvanised S 355 galvanised</p> <p>Stainless Steel: 1.4301 } S 275 resp. 1.4404 } S 355 1.4571 }</p> <p>Designations:</p> <p>HQW 60/60/4, S275, L=xxx – Stainless Steel HQW 60/60/4, S355, L=xxx – Stainless Steel HQW 60/60/4, S275, L=xxx – Stainless Steel HQW 60/60/5, S355, L=xxx – Stainless Steel HQW 60/60/4, S275, L=xxx – galvanised HQW 60/60/4, S355, L=xxx – galvanised HQW 60/60/4, S275, L=xxx – galvanised HQW 60/60/5, S355, L=xxx – galvanised</p> <p>Please find the Length L with the corresponding width of expansion joint in the table of Annex C</p>	<p>HQW 60 / 40</p> <p>Bearing Element Hollow Steel Profile</p> <p>Top View</p>  <p>Dowel Length $L = 290 + f_{max}$</p> <p>60</p> <p>Elevation</p>  <p>Dowel Length $L = 290 + f_{max}$</p>  <p>60</p> <p>40</p> <p>$t = 4 \text{ mm resp. } 5 \text{ mm}$</p> <p>Material: S 275 galvanised S 355 galvanised</p> <p>Stainless Steel: 1.4301 } S 275 resp. 1.4404 } S 355 1.4571 }</p> <p>Designations:</p> <p>HQW 60/60/4, S275, L=xxx – Stainless Steel HQW 60/60/4, S355, L=xxx – Stainless Steel HQW 60/60/4, S275, L=xxx – Stainless Steel HQW 60/60/5, S355, L=xxx – Stainless Steel HQW 60/60/4, S275, L=xxx – galvanised HQW 60/60/4, S355, L=xxx – galvanised HQW 60/60/4, S275, L=xxx – galvanised HQW 60/60/5, S355, L=xxx – galvanised</p> <p>Please find the Length L with the corresponding width of expansion joint in the table of Annex C</p>
<p>Pakon – Trittschallbox HQW</p>	
<p>Product Specification Dimensions and Designation of the Bearing Element</p>	<p>Annex A5</p>

Sound Insulation Box 10 for HQW 60/60
Sound Insulation Box 20 for HQW 60/60 (values in brackets)

Top View

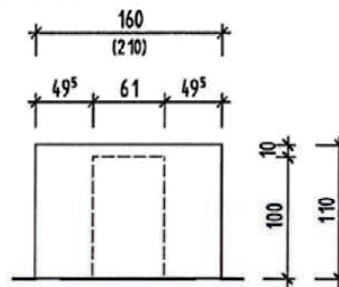

Section 1-1

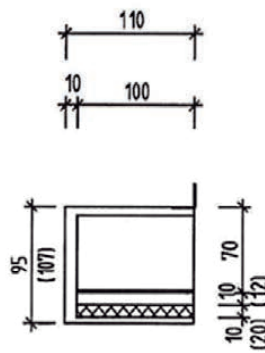

Elevation

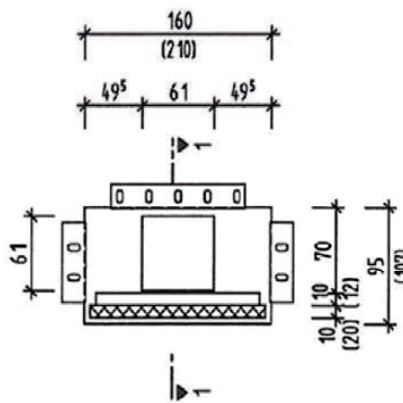

Sound Insulation Box 10 = 10 mm Thickness of elastomeric bearing
Sound Insulation Box 20 = 20 mm Thickness of elastomeric bearing

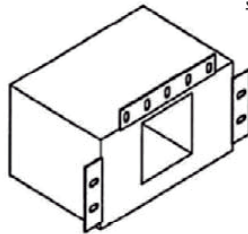

Pakon – Trittschallbox HQW

Product Specification

Dimensions and Designation of the Sound Insulation Box HQW 60/60

Annex A6

Sound Insulation Box 10 for HQW 60/40
Sound Insulation Box 20 for HQW 60/40 (values in brackets)

Top View

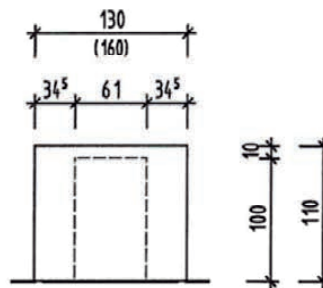

Section 1-1

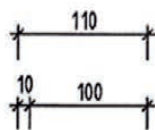

Elevation

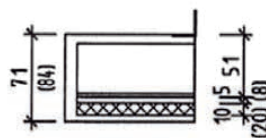
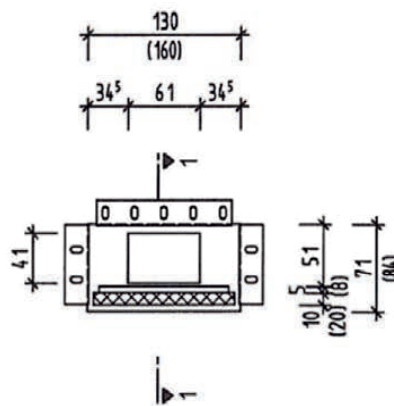

Sound Insulation Box 10 = 10 mm Thickness of elastomeric bearing
Sound Insulation Box 20 = 20 mm Thickness of elastomeric bearing

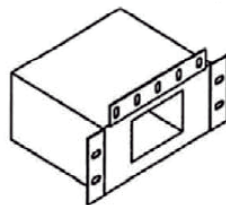

Pakon – Trittschallbox HQW

Product Specification

Dimensions and Designation of the Sound Insulation Box HQW 60/40

Annex A7

Installation

The dowel connector HQW consists of a rectangular hollow steel profile which is running in a sleeve on one side and is supported inside a sound insulation box on the other side of the expansion joint. The sleeve is connected to a steel plate with welded-on steel reinforcement bars. All components are manufactured separately in the factory and assembled on the construction site.

There are several combinations of the HQW building part components shown in Annex A1. In general the HQW dowel system is based on two different hollow steel profiles 60/40 mm and 60/60 mm with wall thicknesses of 4 mm or 5 mm. See also Annex A5.

The sound insulation box, which has to be embedded in a concrete or masonry wall, is available with 10 mm and 20 mm thick elastomer bearings. For a uniform load distribution, a steel plate is arranged between dowel and elastomer bearing inside the box. For installation the box can be placed directly on plane concrete surfaces. In case of masonry walls a mortar bed or a concrete layer is needed for placing the sound insulation box.

The running sleeve is a two-piece synthetic or a one-piece steel component. The sleeve is connected to a gantry steel plate with welded-on steel rebars which serve as supplementary reinforcement.

General dimensions, distances and in-situ steel reinforcement:

The minimum slab thickness is 160 mm for HQW 60/40 respectively 200 mm for HQW 60/60. The regular concrete covers are 20 mm for HQW 60/40 and 35 mm for HQW 60/60. Smaller concrete covers can be chosen in accordance with the exposure classes and the corresponding regulations within EN 1992-1-1, whereas higher concrete covers lead to an increase of the calculational widths of joint and have to be considered along with a reduction of the design resistance values given in Annexes C1 and C2. Further minimum distances are stated in Annex B2.

The HQW dowel system requires in-situ steel reinforcement. In Annexes B4 to B7 the reinforcement positions and the amount of the in-situ reinforcement is given. The steel reinforcement positions 1 to 3 are vertical u-bars. Pos.1 has to be placed perpendicular to the expansion joint next to the supplementary reinforcement of the prefabricated dowel system with a clear distance of 20 mm each. Pos.2 must be placed in parallel with the expansion joint within Pos.1. Also Pos.3 is placed parallel to the expansion joint within Pos.1 near the end of the sleeve.

Pakon – Trittschallbox HQW	
Intended Use Specification	Annex B1

Installation

HQW 60/40 - Dimensions, Distances and In-Situ Steel Reinforcement

		HQW 60/40	
slab thickness	h	≥160 mm	
concrete cover	c _v	20 mm	
axial edge distance	a _R	≥ max [0,75 h ≤ 200 mm; 170 mm]	
horizontal axial dowel distance	a _D	≥ max [1,5 h ≤ 400 mm; 320 mm]	
vertical edge distance	e	≥60 mm	
distance to zero point of slab deformation	a _T	10 mm elastomer	≤ 3 mm / (ε _s + ε _T)
		20 mm elastomer	≤ 6 mm / (ε _s + ε _T)
in-situ reinforcement	A _{sx}	Pos.1	2 x 3 Ø 10 mm
	A _{sy}	Pos.2	1 x 3 Ø 10 mm
	A _{sy}	Pos.3	1 x 2 Ø 10 mm

HQW 60/60 - Dimensions, Distances and In-Situ Steel Reinforcement

		HQW 60/60	
slab thickness	h	≥200 mm	
concrete cover	c _v	35 mm	
axial edge distance	a _R	≥ max [0,75 h ≤ 300 mm; 200 mm]	
horizontal axial dowel distance	a _D	≥ max [1,5 h ≤ 600 mm; 340 mm]	
vertical edge distance	e	ε 70 mm	
distance to zero point of slab deformation	a _T	10 mm elastomer	≤ 3 mm / (ε _s + ε _T)
		20 mm elastomer	≤ 6 mm / (ε _s + ε _T)
in-situ reinforcement	A _{sx}	Pos.1	2 x 3 Ø 12 mm
	A _{sy}	Pos.2	1 x 3 Ø 12 mm
	A _{sy}	Pos.3	1 x 2 Ø 12 mm

Pakon – Trittschallbox HQW

Intended Use
Installation Situation

Annex B2

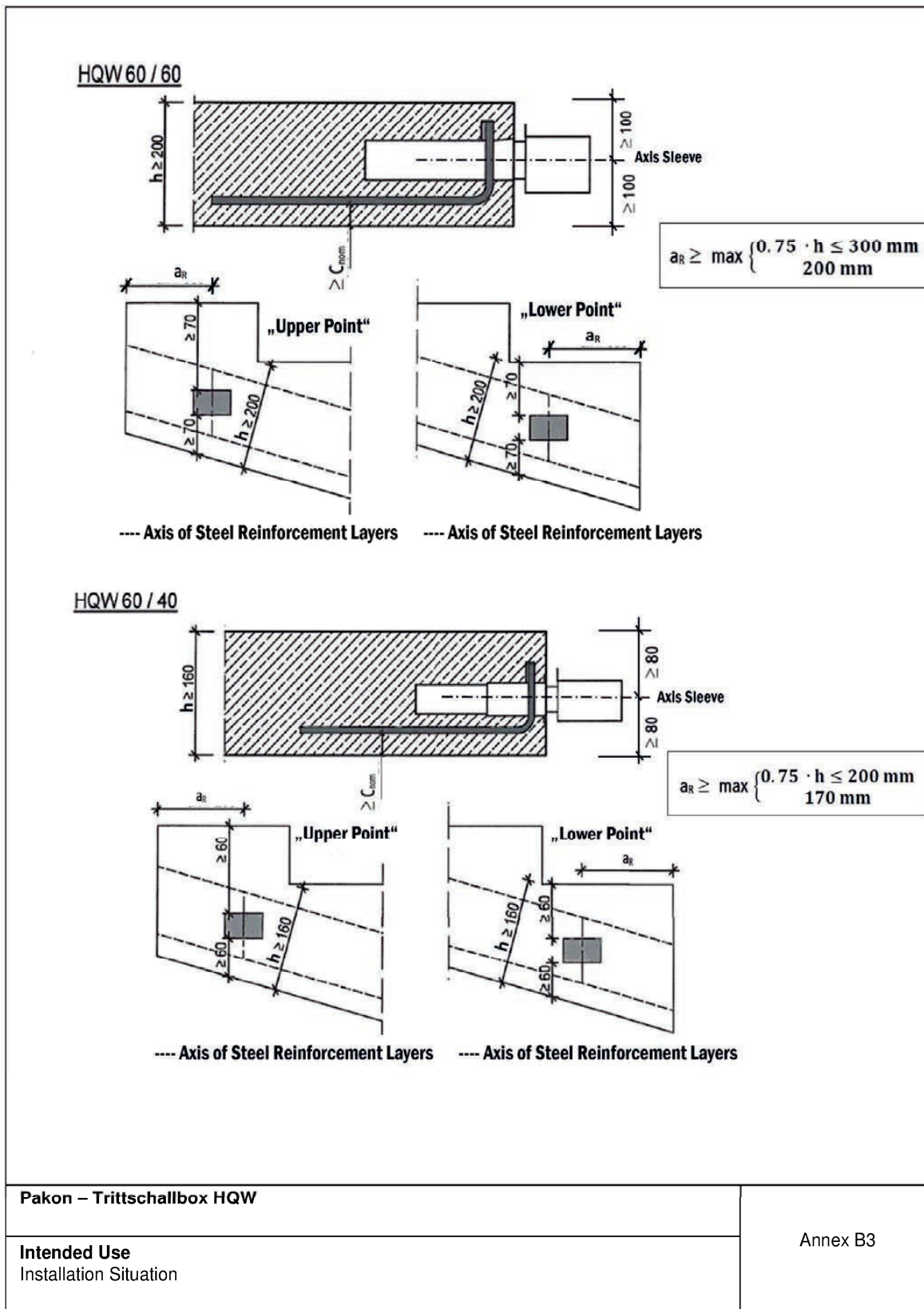

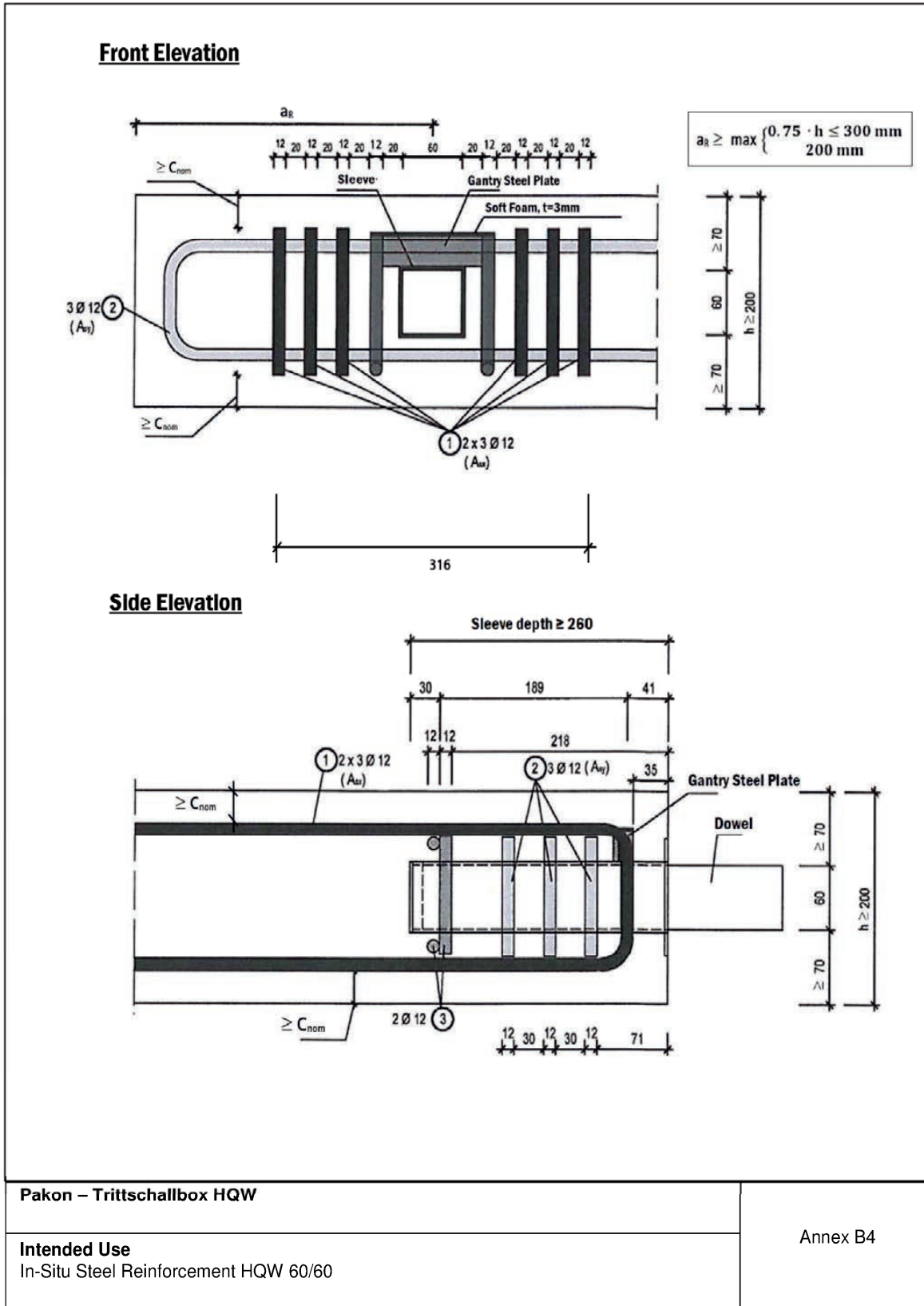

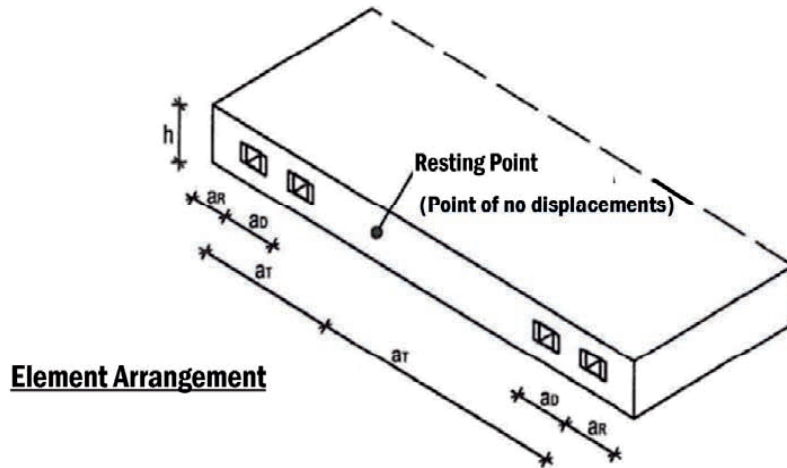

Element Arrangement

Bending Schedule

		HQW 60/60	
slab thickness	h	≥ 200 mm	
concrete cover	c _v	35 mm	
axial edge distance	a _R	≥ max [0,75 h ≤ 300 mm; 200 mm]	
horizontal axial dowel distance	a _D	≥ max [1,5 h ≤ 600 mm; 340 mm]	
vertical edge distance	e	ε 70 mm	
distance to zero point of slab deformation	a _T	10 mm elastomer	≤ 3 mm / (ε _s + ε _r)
		20 mm elastomer	≤ 6 mm / (ε _s + ε _r)
in-situ reinforcement	A _{ox}	Pos.1	2 x 3 Ø 12 mm
	A _{oy}	Pos.2	1 x 3 Ø 12 mm
	A _{oy}	Pos.3	1 x 2 Ø 12 mm

Pos.	Dimensioned Bending Schedule (not to scale)
Pos. 1 = A _{ox}	$h - 2 \times c_{con}$ $2 \times h + l_a$
Pos. 2 = A _{oy} (close to the edge) (H=120 width of Gantry Steel Plate)	$h - 2 \times c_{con} - 2 \times \varnothing A_{ox}$ $a_R + 2 \times h + l_a + H$
Pos. 2 = A _{oy} (away from the edge)	 $2 \times (2 \times h + l_a) + H$
Pos. 3	$h - 2 \times c_{con} - 2 \times \varnothing A_{ox}$ $\min \left\{ \begin{array}{l} (h + l_a) \\ a_R + c_{con} + 70 \text{ mm} \end{array} \right.$

Lap length with local steel reinforcement acc. to EN 1992-1-1

Pakon – Trittschallbox HQW

Intended Use

Element Arrangement, Distances and In-Situ Steel Reinforcement HQW 60/60

Annex B5

Front Elevation

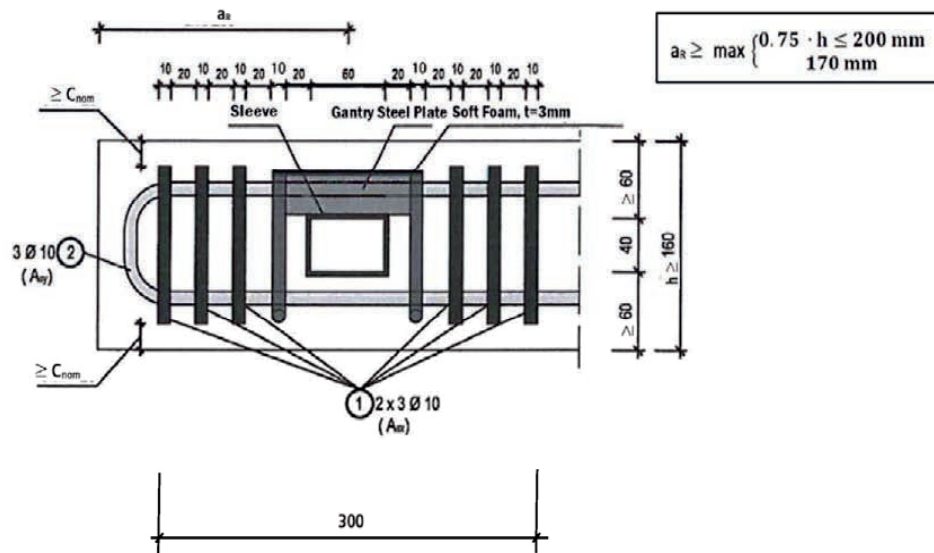

Side Elevation

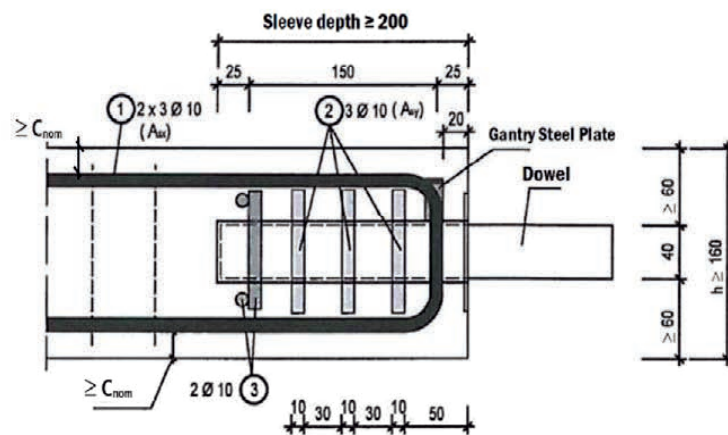

Pakon – Trittschallbox HQW

Intended Use
In-Situ Steel Reinforcement HQW 60/40

Annex B6

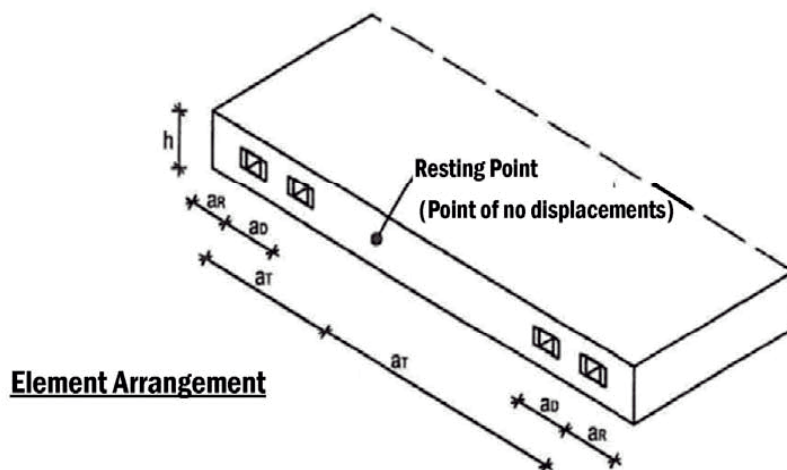

Bending Schedule

		HQW 60/40	
slab thickness	h	≥ 160 mm	
concrete cover	c_v	20 mm	
axial edge distance	a_R	$\geq \max [0,75 h \leq 200$ mm; 170 mm]	
horizontal axial dowel distance	a_D	$\geq \max [1,5 h \leq 400$ mm; 320 mm]	
vertical edge distance	e	≥ 60 mm	
distance to zero point of slab deformation	a_T	10 mm elastomer	≤ 3 mm / ($\epsilon_s + \epsilon_T$)
		20 mm elastomer	≤ 6 mm / ($\epsilon_s + \epsilon_T$)
in-situ reinforcement	A_{sx}	Pos.1	2 x 3 \varnothing 10 mm
	A_{sy}	Pos.2	1 x 3 \varnothing 10 mm
	A_{sy}	Pos.3	1 x 2 \varnothing 10 mm

Pos.	Dimensioned Bending Schedule (not to scale)
Pos. 1 = A_{sx}	$h - 2 \times c_{com}$
Pos. 2 = A_{sy} (close to the edge) ($H=120$ width of Gantry Steel Plate)	$h - 2 \times c_{com} - 2 \times \varnothing A_{sx}$
Pos. 2 = A_{sy} (away from the edge)	
Pos. 3	$h - 2 \times c_{com} - 2 \times \varnothing A_{sx}$

Lap length with local steel reinforcement acc. to EN 1992-1-1

Pakon – Trittschallbox HQW

Intended Use

Element Arrangement, Distances and In-Situ Steel Reinforcement HQW 60/40

Annex B7

Overall Resistance Design Values V_{Rd} for HQW 60/60

HQW 60/60/4 with slab thickness $h \geq 200$ mm and concrete cover $c_v = 35$ mm

width of joint [mm]	dowel length	S275			S355		
		concrete class			concrete class		
		C20/25	C25/30	\geq C30/37	C20/25	C25/30	\geq C30/37
10	350	44,9	44,9	44,9	55,9	58,0	58,0
20	360	41,8	41,8	41,8	53,9	54,0	54,0
30	370	38,9	38,9	38,9	50,2	50,2	50,2
40	380	36,2	36,2	36,2	46,8	46,8	46,8
50	390	33,8	33,8	33,8	43,6	43,6	43,6
60	400	31,5	31,5	31,5	40,6	40,6	40,6
70	410	29,4	29,4	29,4	37,9	37,9	37,9
80	420	27,5	27,5	27,5	35,5	35,5	35,5
90	430	25,8	25,8	25,8	33,3	33,3	33,3
100	440	24,3	24,3	24,3	31,4	31,4	31,4
110	450	23,0	23,0	23,0	29,7	29,7	29,7
120	460	21,8	21,8	21,8	28,2	28,2	28,2

HQW 60/60/5 with slab thickness $h \geq 200$ mm and concrete cover $c_v = 35$ mm

width of joint [mm]	dowel length	S275			S355		
		concrete class			concrete class		
		C20/25	C25/30	\geq C30/37	C20/25	C25/30	\geq C30/37
10	350	54,3	54,3	54,3	55,9	62,9	69,2
20	360	50,6	50,6	50,6	53,9	60,7	65,3
30	370	47,0	47,0	47,0	52,1	58,6	60,7
40	380	43,8	43,8	43,8	50,4	56,5	56,5
50	390	40,8	40,8	40,8	48,8	52,6	52,6
60	400	38,0	38,0	38,0	47,2	49,0	49,0
70	410	35,4	35,4	35,4	45,8	45,8	45,8
80	420	33,1	33,1	33,1	42,8	42,8	42,8
90	430	31,1	31,1	31,1	40,2	40,2	40,2
100	440	29,3	29,3	29,3	37,9	37,9	37,9
110	450	27,7	27,7	27,7	35,8	35,8	35,8
120	460	26,3	26,3	26,3	34,0	34,0	34,0

Advices:

- Intermediate values may be determined by linear interpolation.
- The given concrete strengths are minimum requirements. For higher concrete strengths, the design values for the concrete strength C30/37 are valid.

concrete edge failure

steel failure

Pakon – Trittschallbox HQW

Performance

Load Bearing Capacity and Stability of Sound Insulation Box HQW 60/60

Annex C1

Overall Resistance Design Values V_{Rd} for HQW 60/40

HQW 60/40/4 with slab thickness $h \geq 160$ mm and concrete cover $c_v = 20$ mm

width of joint [mm]	dowel length [mm]	S275			S355		
		concrete class			concrete class		
		C20/25	C25/30	\geq C30/37	C20/25	C25/30	\geq C30/37
10	300	31,3	31,3	31,3	40,4	40,4	40,4
20	310	28,6	28,6	28,6	36,9	36,9	36,9
30	320	26,2	26,2	26,2	33,8	33,8	33,8
40	330	24,0	24,0	24,0	31,0	31,0	31,0
50	340	22,0	22,0	22,0	28,4	28,4	28,4
60	350	20,3	20,3	20,3	26,2	26,2	26,2
70	360	18,7	18,7	18,7	24,2	24,2	24,2
80	370	17,4	17,4	17,4	22,4	22,4	22,4
90	380	16,2	16,2	16,2	20,9	20,9	20,9
100	390	15,2	15,2	15,2	19,6	19,6	19,6
110	400	14,3	14,3	14,3	18,4	18,4	18,4
120	410	13,5	13,5	13,5	17,4	17,4	17,4

HQW 60/40/5 with slab thickness $h \geq 160$ mm and concrete cover $c_v = 20$ mm

width of joint [mm]	dowel length [mm]	S275			S355		
		concrete class			concrete class		
		C20/25	C25/30	\geq C30/37	C20/25	C25/30	\geq C30/37
10	300	37,6	37,6	37,6	40,4	45,5	48,5
20	310	34,3	34,3	34,3	38,6	43,5	44,3
30	320	31,3	31,3	31,3	37,0	40,4	40,4
40	330	28,6	28,6	28,6	35,5	37,0	37,0
50	340	26,3	26,3	26,3	33,9	33,9	33,9
60	350	24,2	24,2	24,2	31,2	31,2	31,2
70	360	22,3	22,3	22,3	28,8	28,8	28,8
80	370	20,7	20,7	20,7	26,7	26,7	26,7
90	380	19,3	19,3	19,3	24,9	24,9	24,9
100	390	18,1	18,1	18,1	23,3	23,3	23,3
110	400	17,0	17,0	17,0	21,9	21,9	21,9
120	410	16,0	16,0	16,0	20,7	20,7	20,7

Advices:

- Intermediate values may be determined by linear interpolation.
- The given concrete strengths are minimum requirements. For higher concrete strengths, the design values for the concrete strength C30/37 are valid.

concrete edge failure

steel failure

Pakon – Trittschallbox HQW

Performance

Load Bearing Capacity and Stability of Sound Insulation Box HQW 60/60

Annex C2

NOTES

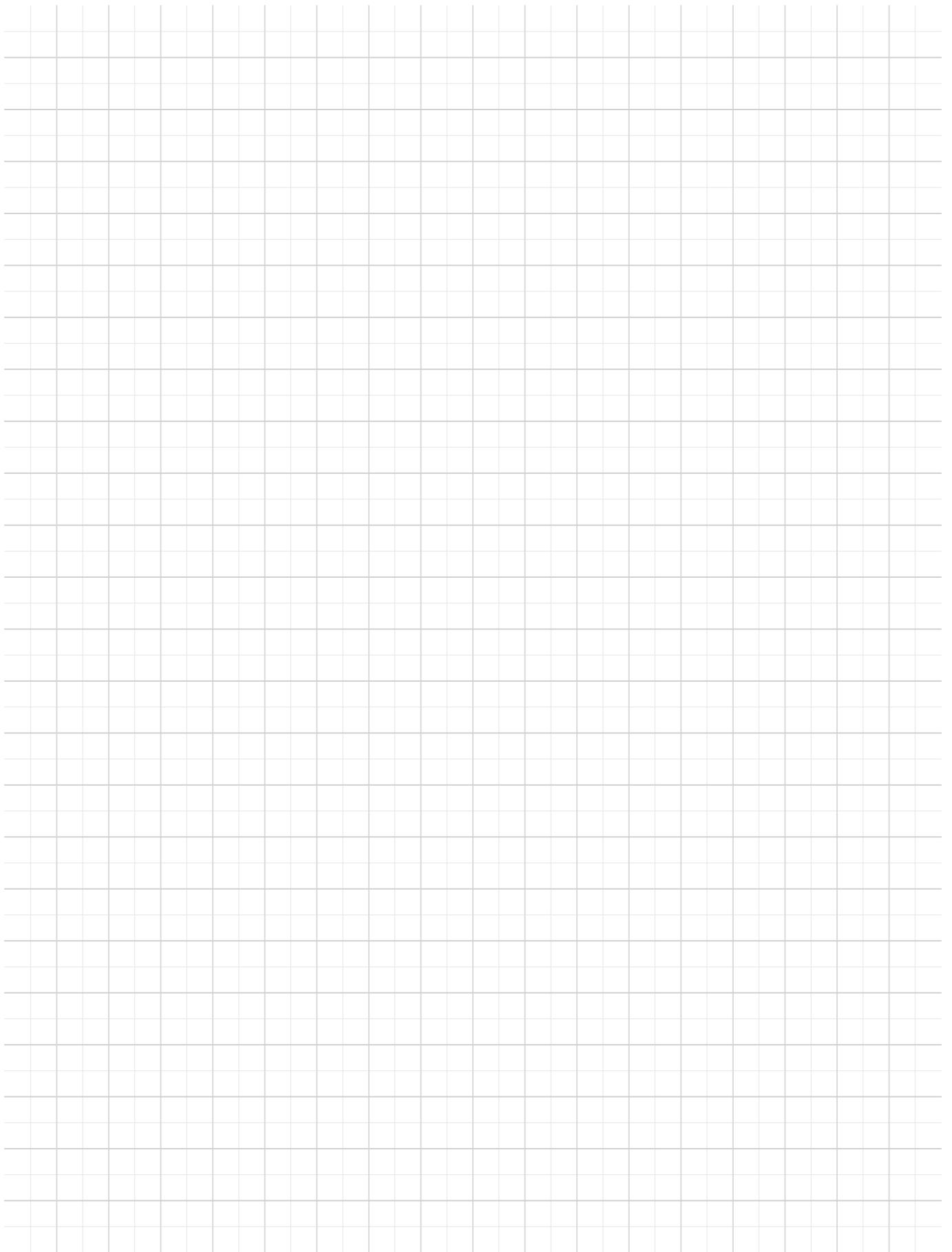



PHILIPP GmbH

Lilienthalstrasse 7-9
63741 Aschaffenburg

☎ + 49 6021 40 27-0
✉ info@philipp-gruppe.de

PHILIPP GmbH

Roßlauer Strasse 70
06869 Coswig/Anhalt

☎ + 49 34903 6 94-0
✉ info@philipp-gruppe.de

PHILIPP GmbH

Sperberweg 37
41468 Neuss

☎ + 49 2131 3 59 18-0
✉ info@philipp-gruppe.de

PHILIPP ACON Hydraulik GmbH

Hinter dem grünen Jäger 3
38836 Dardesheim

☎ + 49 39422 95 68-0
✉ info@philipp-gruppe.de



PHILIPP Vertriebs GmbH

Leogangerstraße 21
5760 Saalfelden / Salzburg

☎ + 43 6582 7 04 01
✉ info@philipp-gruppe.at



Visit us!

www.philipp-gruppe.de